

Plummer Blocks (split)

Series SSN 5 with reinforced base

For self-aligning ball bearings or spherical roller bearings
with adapter sleeve

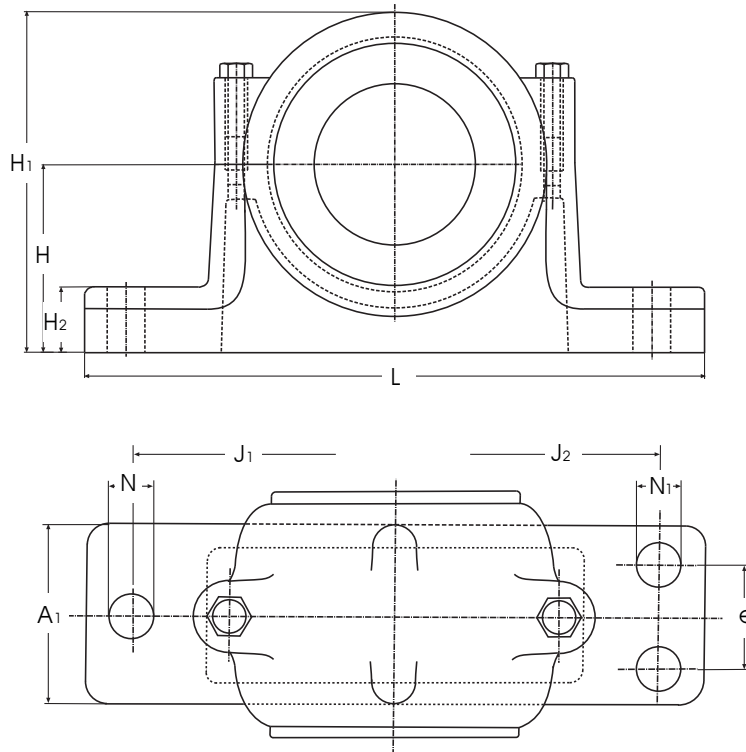

Standard supply is without mounting holes. On request either 2 or 4 bolt holes to dimensions table can be supplied.
Material GGG 40 + GS 45

Housing Ref No	Weight kg	d ₁	H	H ₁	A	A ₂	L mm	A ₁	H ₂	J ₁	J ₂	e	N	N ₁
SSN 508	4,0	35	60	110	85	99	205	60	25	170	160	34	15	11
SSN 509	4,2	40	60	110	85	99	205	60	25	170	160	34	15	11
SSN 510	4,5	45	60	115	90	104	205	60	25	170	160	34	15	11
SSN 511	5,6	50	70	130	95	112	255	70	28	210	200	40	18	14
SSN 512	6,4	55	70	135	105	122	255	70	30	210	200	40	18	14
SSN 513	8,1	60	80	150	110	127	275	80	30	230	220	48	18	14
SSN 515	8,7	65	80	155	115	132	280	80	30	230	220	48	18	14

Series SSN 5 with reinforced base
For self-aligning ball bearings or spherical roller bearings
with adapter sleeve

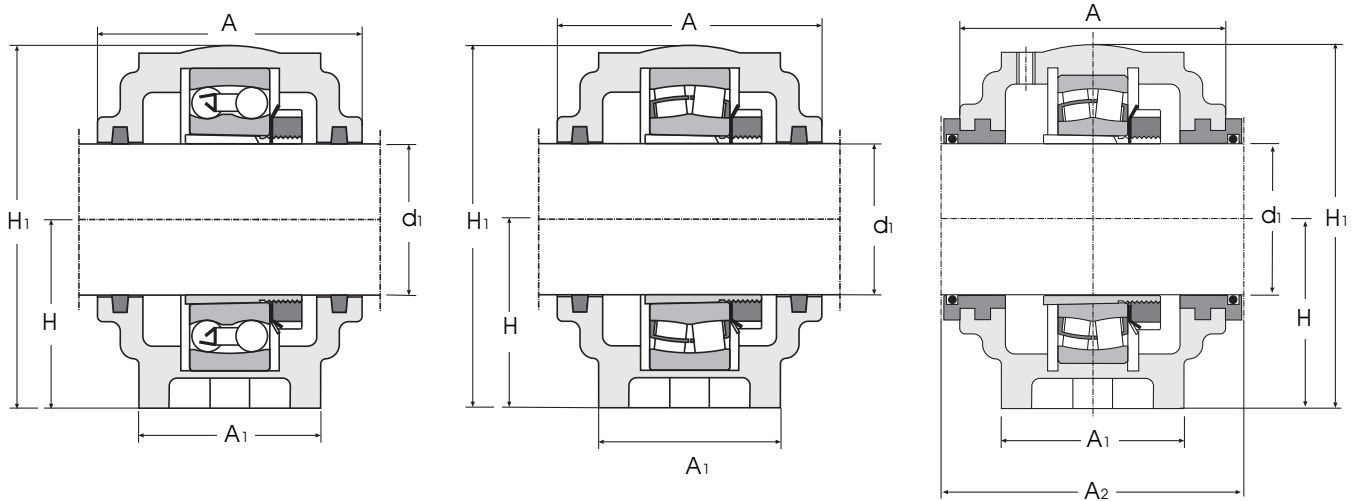

SSN...TS

Housing Ref No	Matching bearing with adapter sleeve		Order ref Fixing ring	Housing with felt seal	Housing with labyrinth seal
SSN 508	1208 K	H 208	2 x FR 7,5/80	SSN 508	SSN 508 TS
	2208 K	H 308	1 x FR 10/80		
	22208 K	H 308	1 x FR 10/80		
SSN 509	1209 K	H 209	2 x FR 6/85	SSN 509	SSN 509 TS
	2209 K	H 309	1 x FR 8/85		
	22209 K	H 309	1 x FR 8/85		
SSN 510	1210 K	H 210	2 x FR 6,5/90	SSN 510	SSN 510 TS
	2210 K	H 310	1 x FR 10/90		
	22210 K	H 310	1 x FR 10/90		
SSN 511	1211 K	H 211	2 x FR 6/100	SSN 511	SSN 511 TS
	2211 K	H 311	1 x FR 8/100		
	22211 K	H 311	1 x FR 8/100		
SSN 512	1212 K	H 212	2 x FR 8/110	SSN 512	SSN 512 TS
	2212 K	H 312	1 x FR 10/110		
	22212 K	H 312	1 x FR 10/110		
SSN 513	1213 K	H 213	2 x FR 10/120	SSN 513	SSN 513 TS
	2213 K	H 313	1 x FR 12/120		
	22213 K	H 313	1 x FR 12/120		
SSN 515	1215 K	H 215	2 x FR 8/130	SSN 515	SSN 515 TS
	2215 K	H 315	1 x FR 10/130		
	22215 K	H 315	1 x FR 10/130		

* for other seals see on page 7

Plummer Blocks (split)

Series SSN 5 with reinforced base

For self-aligning ball bearings or spherical roller bearings
with adapter sleeve

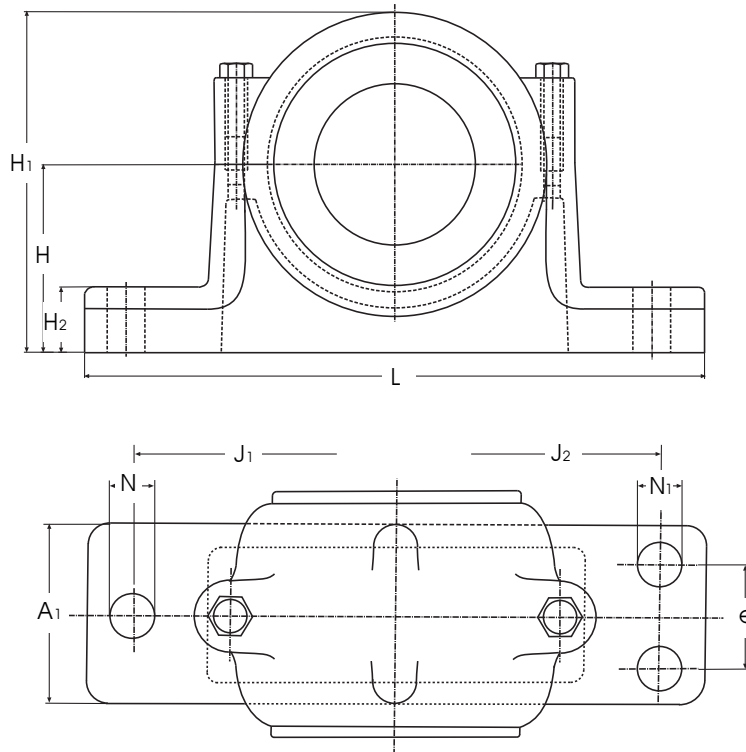

Standard supply is without mounting holes. On request either 2 or 4 bolt holes to dimensions table can be supplied.
Material GGG 40 + GS 45

Housing Ref No	Weight kg	d ₁	H	H ₁	A	A ₂	L	A ₁	H ₂	J ₁	J ₂	e	N	N ₁
SSN 516	11,1	70	95	175	120	137	315	90	32	260	252	52	22	18
SSN 517	12,1	75	95	185	125	142	320	90	32	260	252	52	22	18
SSN 518	14,8	80	100	195	145	162	345	100	35	290	280	58	22	18
SSN 520	19,3	90	112	215	160	178	380	110	40	320	300	66	26	18
SSN 522	24,7	100	125	240	175	193	410	120	45	350	320	74	26	18
SSN 524	28,0	110	140	270	185	203	410	120	45	350	330	74	26	18
SSN 526	35,5	115	150	290	190	208	445	130	50	380	370	80	28	22

Plummer Blocks (split)

Series SSN 5 with reinforced base

For self-aligning ball bearings or spherical roller bearings with adapter sleeve

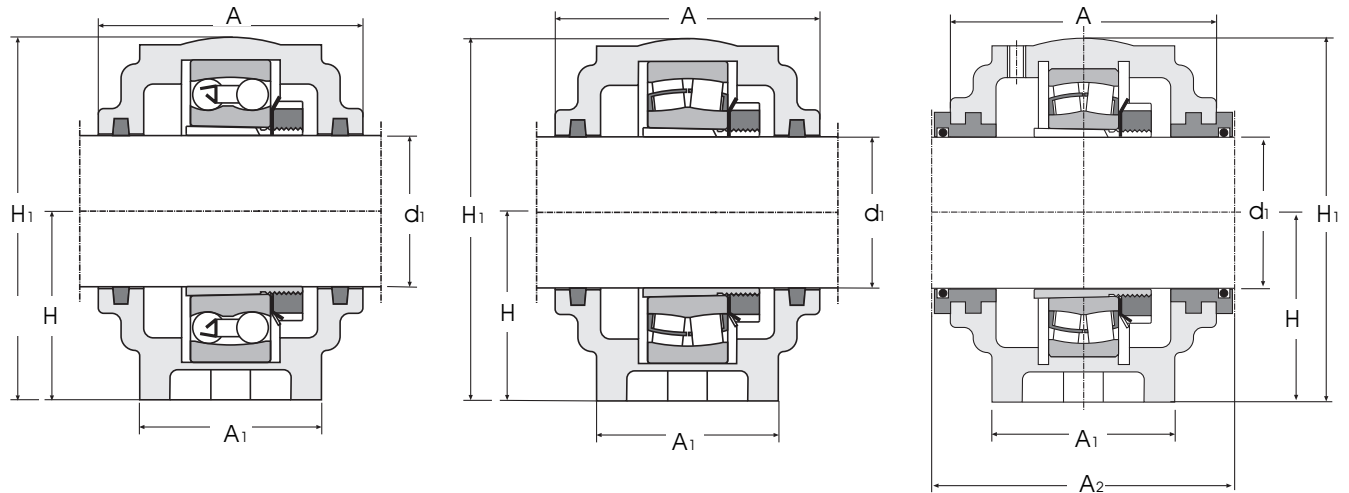

SSN...TS

Housing Ref No	Matching bearing with adapter sleeve	Order ref Fixing ring	Housing with felt seal	Housing with labyrinth seal
SSN 516	1216 K H 216	2 x FR 8,5/140	SSN 516	SSN 516 TS
	2216 K H 316	1 x FR 10/140		
	22216 K H 316	1 x FR 10/140		
SSN 517	1217 K H 217	2 x FR 9/150	SSN 517	SSN 517 TS
	2217 K H 317	1 x FR 10/150		
	22217 K H 317	1 x FR 10/150		
SSN 518	1218 K H 218	2 x FR 16,2/160	SSN 518	SSN 518 TS
	2218 K H 318	2 x FR 11,2/160		
	22218 K H 318	2 x FR 11,2/160		
	23218 K H 2318	1 x FR 10/160		
SSN 520	1220 K H 220	2 x FR 18,1/180	SSN 520	SSN 520 TS
	2220 K H 320	2 x FR 12,1/180		
	22220 K H 320	2 x FR 12,1/180		
	23220 K H 2320	1 x FR 10/180		
SSN 522	1222 K H 222	2 x FR 21/200	SSN 522	SSN 522 TS
	2222 K H 322	2 x FR 13,5/200		
	22222 K H 322	2 x FR 13,5/200		
	23222 K H 2322	1 x FR 10/200		
SSN 524	22224 K H 3124	2 x FR 14/215	SSN 524	SSN 524 TS
	23224 K H 2324	1 x FR 10/215		
SSN 526	22226 K H 3126	2 x FR 13/230	SSN 526	SSN 526 TS
	23226 K H 2326	1 x FR 10/230		

* for other seals see on page 7

Plummer Blocks (split)

Series SSN 5 with reinforced base

For self-aligning ball bearings or spherical roller bearings
with adapter sleeve

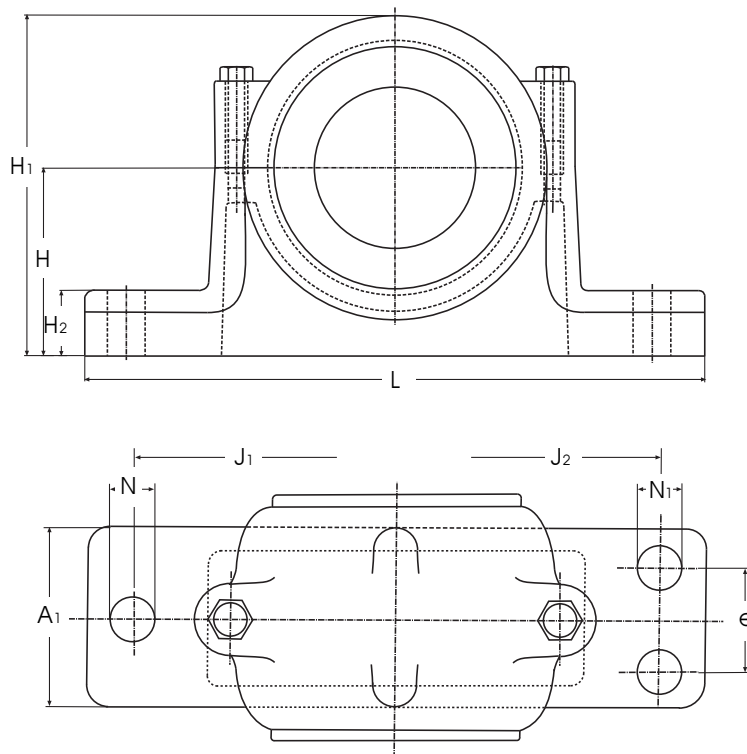

Standard supply is without mounting holes. On request either 2 or 4 bolt holes to dimensions table can be supplied.
Material GGG 40 + GS 45

Housing Ref No	Weight kg	d_1	H	H_1	A	A_2	L mm	A_1	H_2	J_1	J_2	e	N	N_1
SSN 528	45,0	125	150	305	205	223	500	150	50	420	400	92	35	26
SSN 530	53,5	135	160	325	220	238	530	160	60	450	430	100	35	26
SSN 532	62,0	140	170	345	235	253	550	160	60	470	450	100	35	26

Plummer Blocks (split)

Series SSN 5 with reinforced base

For self-aligning ball bearings or spherical roller bearings
with adapter sleeve

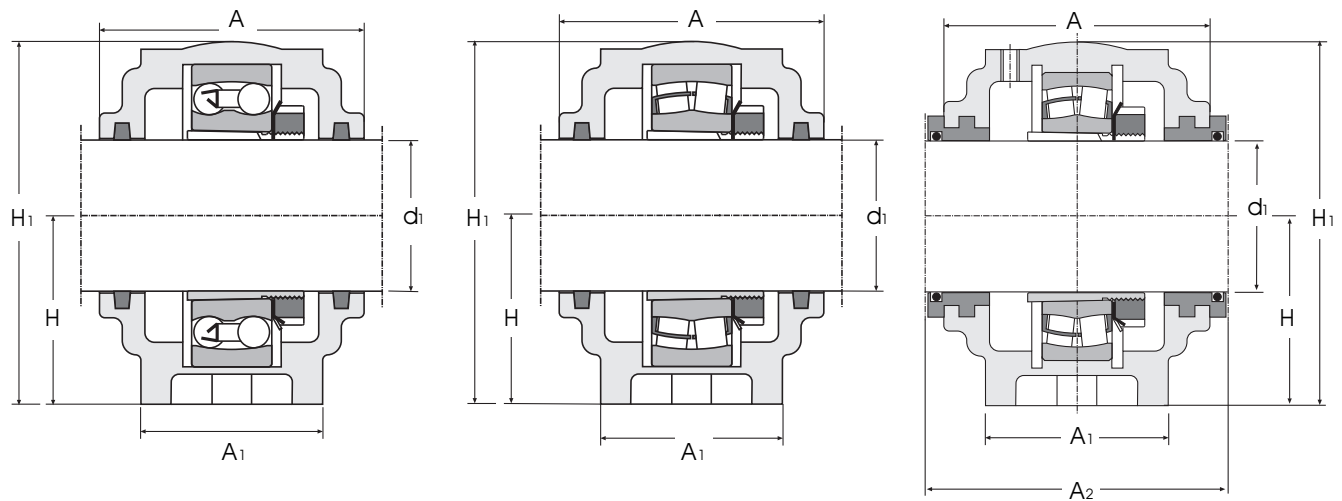

SSN...TS

Housing Ref No	Matching bearing with adapter sleeve	Order ref Fixing ring	Housing with felt seal	Housing with labyrinth seal
SSN 528	22228 K H 3128	2 x FR 15/250	SSN 528	SSN 528 TS
	23228 K H 2328	1 x FR 10/250		
SSN 530	22230 K H 3130	2 x FR 16,5/270	SSN 530	SSN 530 TS
	23230 K H 2330	1 x Fr 10/270		
SSN 532	22232 K H 3132	2 x FR 17/290	SSN 532	SSN 530 TS
	23232 K H 2332	1 x FR 10/290		

* for other seals see on page 7

Plummer Blocks (split)

Series SSN 2 with reinforced base

For self-aligning ball bearings or spherical roller bearings
with cylindrical bore

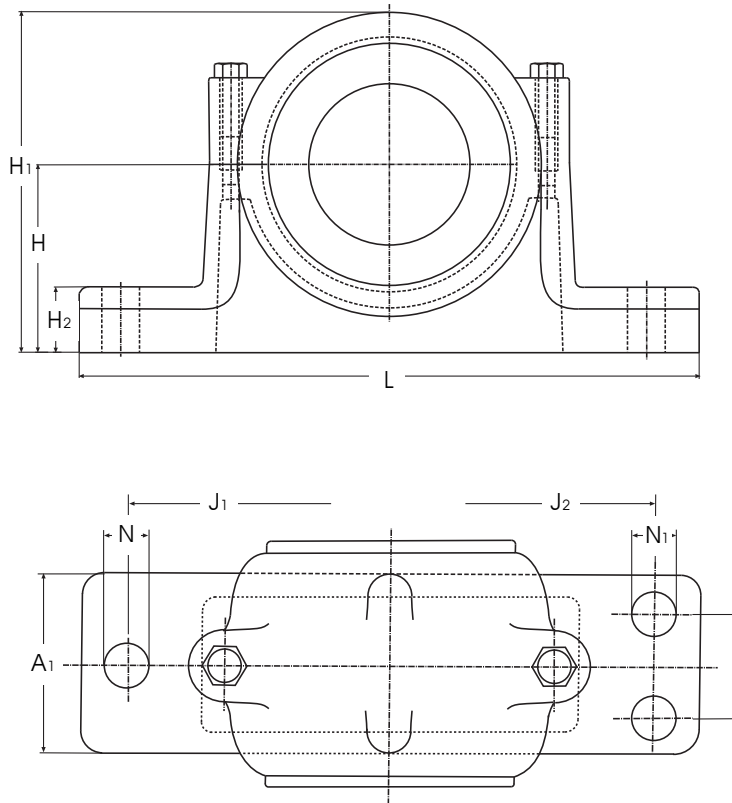

Standard supply is without mounting holes. On request either 2 or 4 bolt holes to dimensions table can be supplied.
Material GGG 40 + GS 45

Housing Ref No	Weight kg	d ₁	d ₂	H	H ₁	A	L mm	A ₁	H ₂	e	J ₁	J ₂	N	N ₁
SSN 208	3,7	40	50	60	110	85	205	60	25	34	170	160	15	11
SSN 209	3,9	45	55	60	110	85	205	60	25	34	170	160	15	11
SSN 210	4,2	50	60	60	115	90	205	60	25	34	170	160	15	11
SSN 211	5,3	55	65	70	130	95	255	70	28	40	210	200	18	14
SSN 212	6,1	60	70	70	135	105	255	70	30	40	210	200	18	14
SSN 213	7,7	65	75	80	150	110	275	80	30	48	230	220	18	14
SSN 215	8,3	75	85	80	155	115	280	80	30	48	230	220	18	14

Plummer Blocks (split)

Series SSN 2 with reinforced base
 For self-aligning ball bearings or spherical roller bearings
 with cylindrical bore

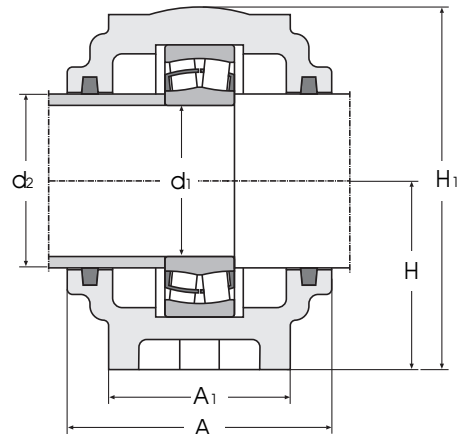
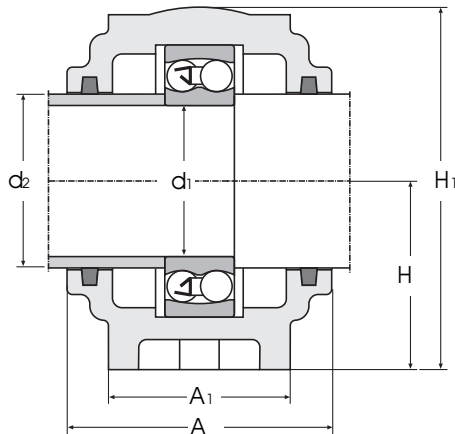

Housing Ref No	Matching bearing with adapter sleeve	Fixing ring
SSN 208	1208	2 x FR 7,5/80
	2208	1 x FR 10/80
	22208	1 x FR 10/80
SSN 209	1209	2 x FR 6/85
	2209	1 x FR 8/85
	22209	1 x FR 8/85
SSN 210	1210	2 x FR 6,5/90
	2210	1 x FR 10/90
	22210	1 x FR 10/90
SSN 211	1211	2 x FR 6/100
	2211	1 x FR 8/100
	22211	1 x FR 8/100
SSN 212	1212	2 x FR 8/110
	2212	1 x FR 10/110
	22212	1 x FR 10/110
SSN 213	1213	2 x FR 10/120
	2213	1 x FR 12/120
	22213	1 x FR 12/120
SSN 215	1215	2 x FR 8/130
	2215	1 x FR 10/130
	22215	1 x FR 10/130

Plummer Blocks (split)

Series SSN 2 with reinforced base

For self-aligning ball bearings or spherical roller bearings
with cylindrical bore

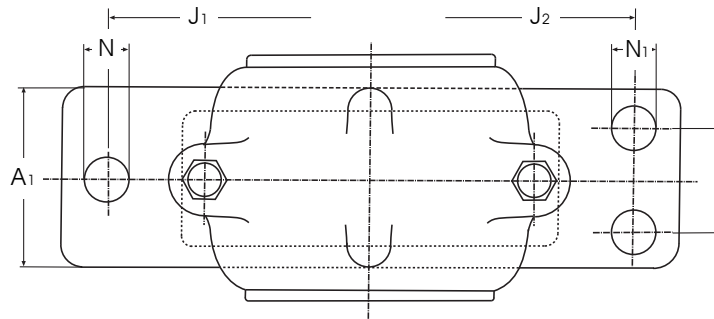
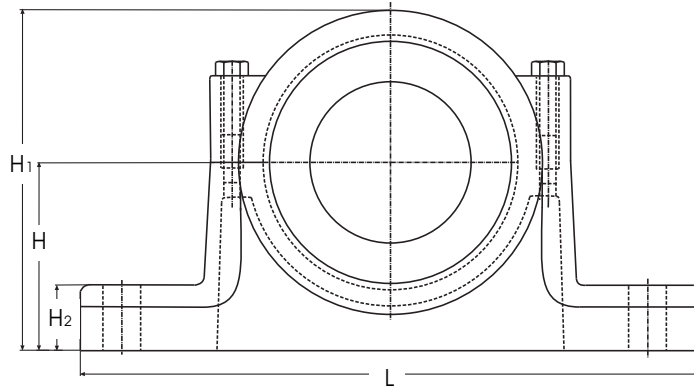

Standard supply is without mounting holes. On request either 2 or 4 bolt holes to dimensions table can be supplied.
Material GGG 40 + GS 45

Housing Ref No	Weight kg	d ₁	d ₂	H	H ₁	A	L mm	A ₁	H ₂	e	J ₁	J ₂	N	N ₁
SSN 216	10,5	80	90	95	175	120	315	90	32	52	260	252	22	18
SSN 217	11,5	85	95	95	185	125	320	90	32	52	260	252	22	18
SSN 218	14,2	90	100	100	195	145	345	100	35	58	290	280	22	18
SSN 220	18,5	100	115	112	215	160	380	110	40	66	320	300	26	18
SSN 222	23,6	110	125	125	240	175	410	120	45	74	350	320	26	18
SSN 224	27,0	120	135	140	270	185	410	120	45	74	350	330	26	18

Plummer Blocks (split)

Series SSN 2 with reinforced base
For self-aligning ball bearings or spherical roller bearings
with cylindrical bore

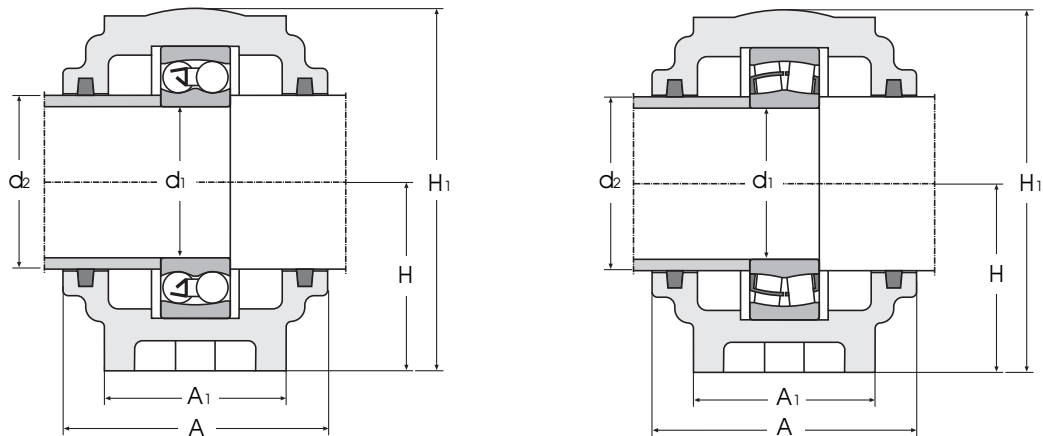

Housing Ref No	Matching bearing with adapter sleeve	Fixing ring
SSN 216	1216	2 x FR 8,5/140
	2216	1 x FR 10/140
	22216	1 x FR 10/140
SSN 217	1217	2 x FR 9/150
	2217	1 x FR 10/150
	22217	1 x FR 10/150
SSN 218	2128	2 x FR 16,2/160
	2218	2 x FR 11,2/160
	22218	2 x FR 11,2/160
	23218	1 x FR 10/160
SSN 220	1220	2 x FR 19,1/180
	2220	2 x FR 12,1/180
	22220	2 x FR 12,1/180
	23220	1 x FR 10/180
SSN 222	1222	2 x FR 21/200
	2222	2 x FR 13,5/200
	22222	2 x FR 13,5/200
	23222	1 x FR 10/200
SSN 224	22224	2 x FR 14/215
	23224	1 x FR 10/215

Plummer Blocks (split)

Series SSN 2 with reinforced base

For self-aligning ball bearings or spherical roller bearings
with cylindrical bore

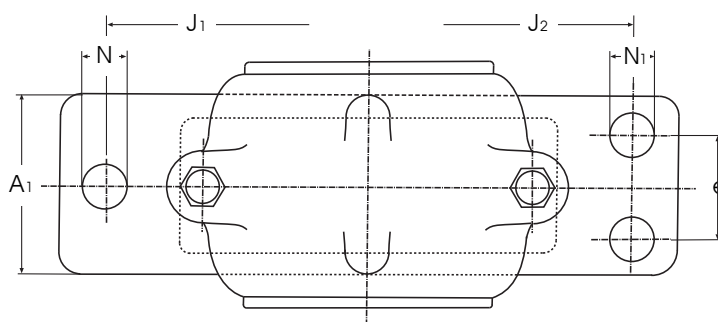
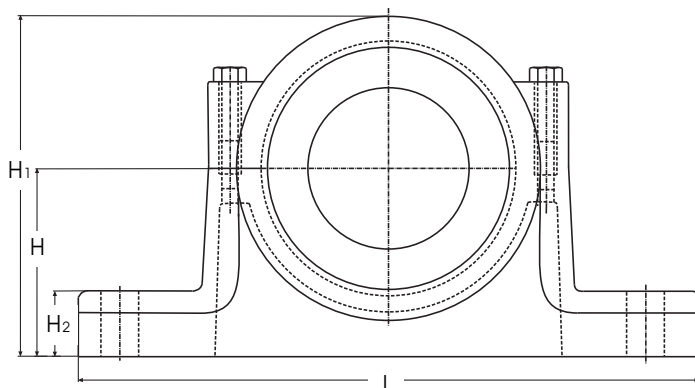

Standard supply is without mounting holes. On request either 2 or 4 bolt holes to dimensions table can be supplied.
Material GGG 40 + GS 45

Housing Ref No	Weight kg	d_1	d_2	H	H_1	A	L mm	A_1	H_2	e	J_1	J_2	N	N_1
SSN 226	34,5	130	145	150	290	190	445	130	50	80	380	370	28	22
SSN 228	43,5	140	155	150	305	205	500	150	50	92	420	400	35	26
SSN 230	52,0	150	165	160	325	220	530	160	60	100	450	430	35	26
SSN 232	60,0	160	175	170	345	235	550	160	60	100	470	450	35	26

Plummer Blocks (split)

Series SSN 2 with reinforced base
 For self-aligning ball bearings or spherical roller bearings
 with cylindrical bore

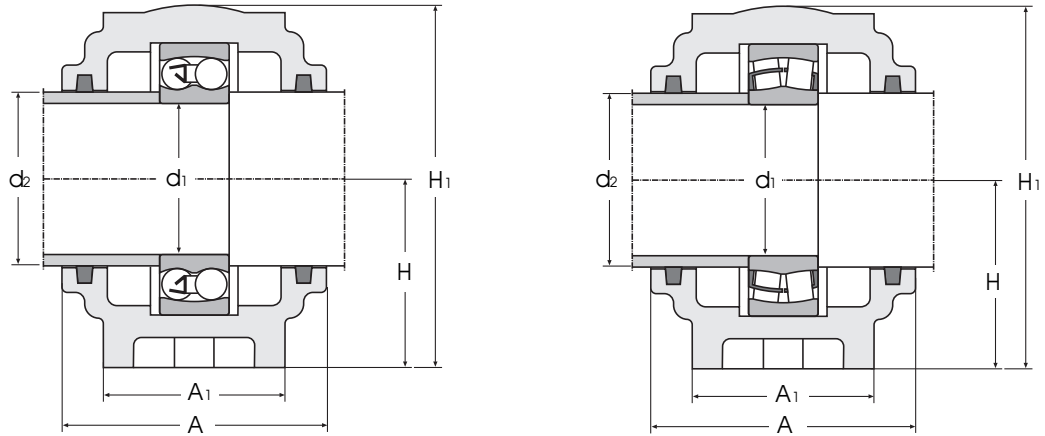

Housing Ref No	Matching bearing with adapter sleeve	Fixing ring
SSN 226	22226	2 x FR 13/230
	23226	1 x FR 10/230
SSN 228	22228	2 x FR 15/250
	23228	2 x FR 10/250
SSN 230	22230	2 x FR 16,5/270
	23230	1 x FR 10/270
SSN 232	22232	2 x FR 17/290
	23232	1 x FR 10/290

* for other seals see on page 7