

This unsplit plummer block bearing housing is designed for use with self aligning ball bearings with extended inner ring. The sealing rings are made from grey cast iron and fitted with felt strip.

The outer ring of the bearing is located axially by the sealing ring. The inner ring of the bearing extends approximately 1 cm over each end. This prevents contact between machine parts with the housing. The movement of the inner ring as well as axial location results from the use of a set screw which locates in a groove on one side of the inner ring. TN housings are made from GG20. A high grade grease is recommended for lubrication of these housings.

Breaking Loads for TN Plummer Block Housings

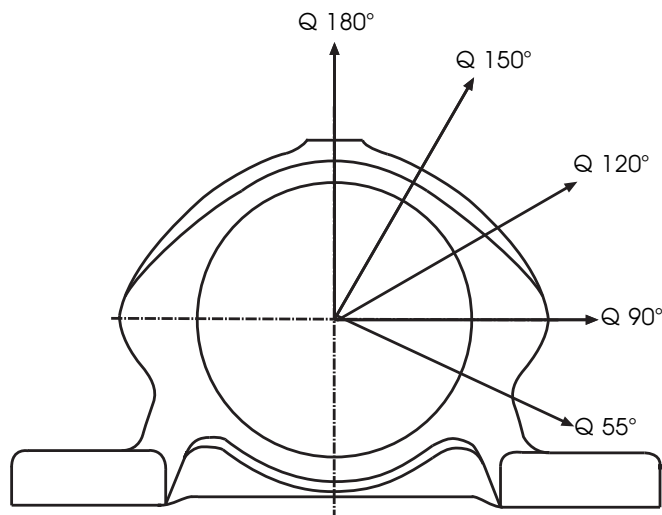

Housing Ref	Breaking Load kN				
	Q 180°	Q 150°	Q 120°	Q 90°	Q 55°
TN 204	25	21	24	41	130
TN 205	29	25	20	49	135
TN 206	41	34	40	65	145
TN 207	41	34	40	68	145
TN 208	60	50	56	95	165
TN 209	68	56	65	105	200
TN 210	76	65	75	125	200
TN 211	95	80	90	150	210
TN 212	106	90	100	175	225

Plummer Block Bearing Housing (unsplit)

Series TN 2

for self aligning ball bearings with extended inner ring

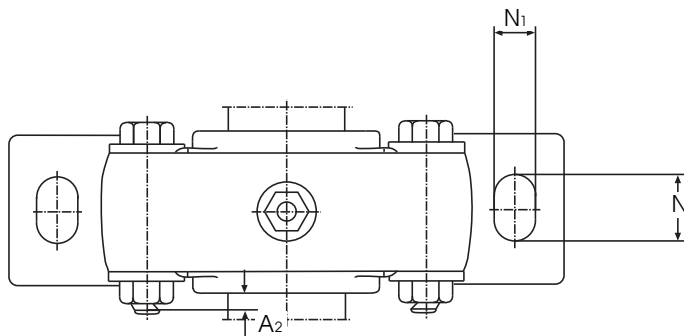
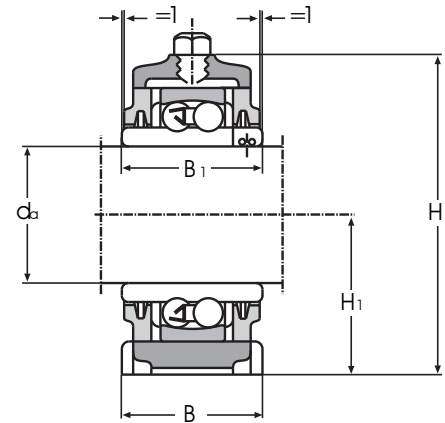
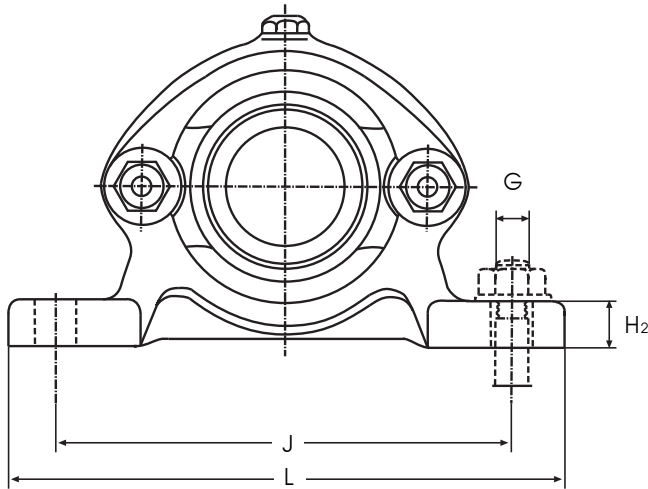

Housing Ref	Bearing Ref	Weight kg	d_a	H_1	H	B_1	L	B mm	H_2	A_2	J	N	N_1	G	Grease quantity First filling/kg
TN 204	11204	1,10	20	40	74	40	145	42	12	6,5	115	14	20	M12	0,005
TN 205	11205	1,14	25	40	77	44	150	42	12	8,5	120	14	20	M12	0,005
TN 206	11206	1,77	30	50	93	48	165	48	14	10,0	130	14	24	M12	0,010
TN 207	11207	1,89	35	50	98	52	180	48	14	8,0	145	14	24	M12	0,015
TN 208	11208	2,40	40	55	108	56	195	52	16	8,5	160	14	24	M12	0,020
TN 209	11209	2,70	45	60	116	58	210	56	16	7,5	175	14	24	M12	0,020
TN 210	11210	3,06	50	60	120	58	210	56	16	6,0	175	14	24	M12	0,025
TN 211	11211	3,91	55	65	129	60	230	62	18	8,0	190	17	27	M16	0,040
TN 212	11212	4,63	60	70	140	62	245	66	18	10,0	205	17	27	M16	0,050