

Flanged Double Bearing

Series ZLFB...N

Regreaseable

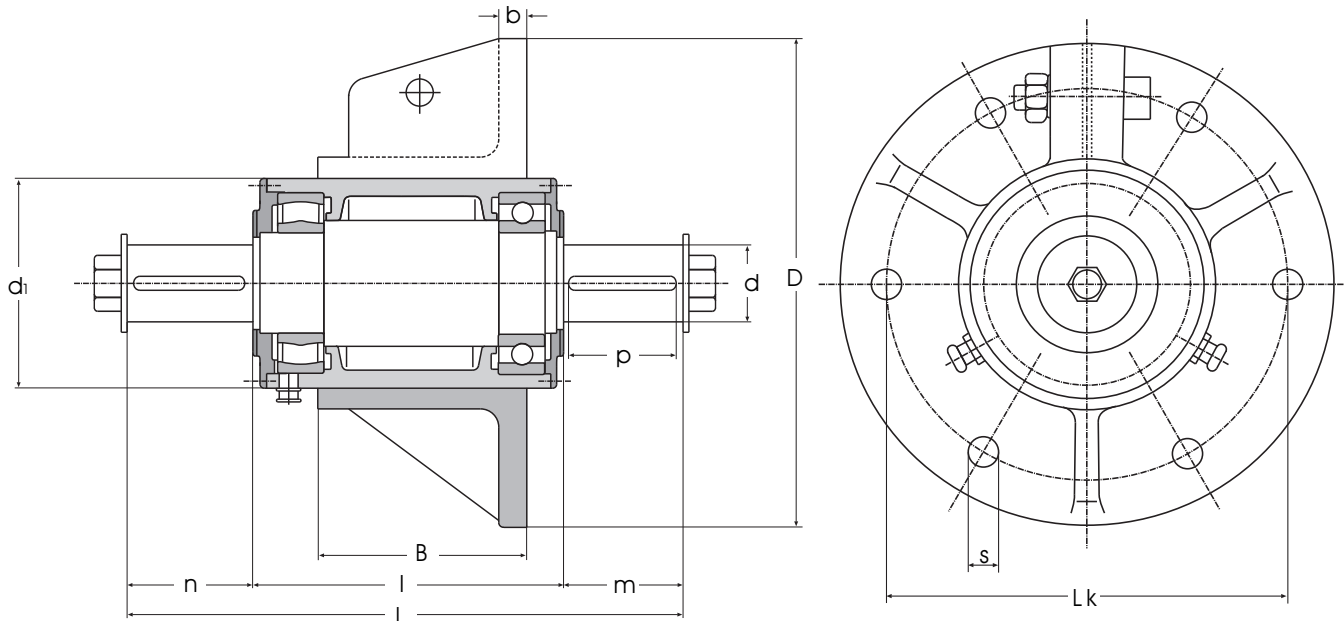

Two bearing - Flange ZLFB..NS regreaseable

Series ZLFB..NS flanged bearings are supplied as a complete unit comprising housing, clamping flange, shaft complete with feather key and end disc, drive end cylindrical roller bearing and impeller end ball bearing.

Regreasing of the bearings is carried out independently using grease nipples at each bearing position.

The bearings are pre-greased with Kübler Staburags NBU 12 able to withstand operating temperatures of 120° C and intermittent peak temperatures of 160° C.

The clamping flange allows axial adjustment of the impeller.

Housing Ref No	Dimensions in mm											Fitted bearing		Weight kg	
	dk6	d1	D	6 hole			n	m	l	B	b	p	Impeller end		Drive end
ZLFB 20 N	18	70	125	110	9,5	190	42,5	37,5	110	50	10	28	6205 C3	NU 2205 C3	3,4
ZLFB 25 N	22	70	125	110	9,5	190	42,5	37,5	110	50	10	28	6205 C3	NU 2205 C3	3,5
ZLFB 30 N	28	90	190	160	11,5	217	41,0	51,0	125	70	14	36	6207 C3	NU 2207 C3	7,9
ZLFB 40 N	35	105	225	190	11,5	265	46,0	66,0	153	90	16	40	6209 C3	NU 2209 C3	14,1
ZLFB 50 N	45	125	300	265	11,5	325	75,0	75,0	175	100	16	56	6211 C3	NU 2211 C3	26,0
ZLFB 60 N	55	150	350	310	11,5	400	90,0	90,0	220	150	20	80	6312 C3	NU 312 C3	46,0